

Hybrid SHM-SHE Pulse Amplitude Modulation for High Power Four-Leg Inverter

Mohammad Sharifzadeh, Hani Vahedi, *Student, IEEE*, Ramon Portillo, *Member, IEEE*, Mohammad Khenar, Abdolreza Sheikholeslami, Leopoldo G. Franquelo, *Fellow, IEEE*, Kamal Al-Haddad, *Fellow, IEEE*

Abstract—This paper presents a hybrid SHM-SHE switching technique based on pulse amplitude modulation (PAM) concept. It has been applied on a 4-leg NPC inverter to eliminate and mitigate more harmonic orders than recently proposed hybrid SHM-SHE-PWM method while generating switching pulses at the same frequency. In conventional SHE and SHM techniques, equations are solved to attain the switching angles. Regarding the PAM, value of inverter DC voltage can be considered as an additional degree of freedom by which the flexibility of such techniques would be increased maintaining the switching frequency. In the proposed SHM-SHE-PAM, the conventional equations are reformulated to obtain constant switching angles for a vast range of modulation index (m_a) applied on a 4-leg NPC inverter. Switching pulses of the 3 phase legs and the 4th leg are calculated to mitigate the non-triplen harmonics and eliminate the triplen ones, respectively. Due to the unique switching angles valid in the whole range for m_a , the calculation time and volume (storage capacity) are significantly reduced leading to a simpler controller implementable on a low risk and cheap AVR Chip. Experimental tests results of a 4-leg NPC inverter as UPS application prove the good dynamic performance and accuracy of the proposed implemented switching technique in producing associated pulses for the inverter switches at very low frequency to mitigate/eliminate undesired harmonic orders from the output phase/line voltage waveforms without using bulky filters.

Index Terms— Hybrid SHM-SHE-PWM, Hybrid SHM-SHE-PAM, Four-leg NPC inverter, Selective Harmonic Elimination, Selective Harmonic Mitigation.

I. INTRODUCTION

Nowadays, the conventional multilevel voltage source inverters have been redesigned as a four-wire configuration to deal with critical asymmetrical load types such as single phase, time varying and nonlinear [1, 2].

Manuscript received August 28, 2015; revised December 8, 2015; accepted January 13, 2016. This work has been supported by the Canadian Research Chair in Electric Energy Conversion and Power Electronics (CRC-EECP) and in part by the Natural Sciences and Engineering Research Council of Canada (NSERC).

M. Sharifzadeh, M. Khenar and A. Sheikholeslami are with the Babol Noshirvani University of Technology, Department of Computer and Electrical Engineering, Babol, Iran (email: muhammad.sharifzade@gmail.com, mohammadkhenar@gmail.com, asheikh@nit.ac.ir).

H. Vahedi and K. Al-Haddad are with the Ecole de Technologie Supérieure, University of Quebec, Montreal, Quebec, Canada H3C 1K3 (email: hani.vahedi@etsmtl.ca, kamal.al-haddad@etsmtl.ca)

R. Portillo and L. G. Franquelo are with the Electronic Engineering Department, University of Seville, 41092 Seville, Spain (email: ramonpg@us.es, lgfranquelo@ieec.org)

Regarding the direct control on the neutral current, four-leg NPC inverter has simple DC-link voltage balancing and lower capacitor voltage ripple. Moreover, this topology can utilize the maximum possible DC input voltage [3-5]. But, employing higher number of power semiconductor switches leads to increased switching and conducting power losses in the case of high switching frequency control strategy [6-8].

Selective Harmonic Elimination (SHE) modulation technique is truly executable in low switching frequency to eliminate specific low order harmonics [9-12]. SHE is a mathematical control strategy that is based on output voltage waveform to compute switching angles in an offline way [13-15]. In recent years, SHE has been introduced for four-leg inverters [16-19]. According to the proposed SHE technique, equations for three phase legs are determined to eliminate non-triplen harmonics while fourth leg equations are defined to remove the remaining triplen harmonics of three phase legs in the phase voltage. Despite this, SHE has no control on non-eliminated harmonics and voltage THD. Hence, the SHM modulation technique has been introduced in [11, 12, 20] to overcome some of the SHE's drawbacks by mitigating non-triplen harmonics in a vast range. The proven low switching frequency of these two modulation techniques make it appealing to be used on multilevel converters in high power applications.

In [21], a hybrid SHM-SHE technique has been proposed to use SHM in phase legs instead of SHE in order to mitigate low order non-triplen harmonics below the limits imposed by the standards EN 50160 and CIGRE WG 36-05 [22, 23], while the fourth leg's pulses are calculated to eliminate triplen harmonics consistent with SHE principle. Therefore, obtained angles in the SHM-SHE are more optimized compared to the pure SHE in [16-18]. However, in SHM-SHE which is based on PWM technique, only the switching angles have been considered as degrees of freedom in the equations. Thus, if more harmonics are needed to suppress, more angles have to be assumed in the equations lead to an increased switching frequency. Besides switching angles, the value of DC input voltage can be considered as an extra degree of freedom in order to find better results without increasing the switching frequency. As a background information, the idea of assuming DC voltage in the equations has been taken into account in two/multilevel SHE/SHM-PWM [24-26]. The main objectives in those works have been concentrated on finding more continuous and smoother trajectory for switching angles as well as eliminating more harmonic orders proportional to the number of existing DC sources. However, up to now none of

them succeeded to present a general formulation to guarantee achieving these aims. In addition, the potential impacts of this idea on items such as voltage THD and inverter's controller have not been investigated.

In this paper, a generalized formula for hybrid SHM-SHE technique is proposed considering both angles and DC voltage as degree of freedom in the equations to ensure achieving quite smooth trajectory for switching angles. New equations of hybrid SHM-SHE are adjusted to solve just for one time to set a constant value for each angle in the given range of modulation index (m_a). Compared to the hybrid SHM-SHE-PWM, off-line computations time and storage capacity has been decreased noticeably. As a result, it is provided the possibility of utilizing simpler and cheaper hardware controller like AVR for implementing this modulation technique. The value of DC input voltage is also computed with respect to the m_a so that it varies linearly proportional to the m_a . Owing to the fact that only pulses amplitudes of the output voltage are changed, the proposed control strategy is called SHM-SHE-PAM (Pulse Amplitude Modulation). The obtained results of SHM-SHE-PAM demonstrate a significant improvement in the harmonic content of output voltage waveform. Indeed, in an identical switching frequency position with SHM-SHE-PWM all non-triplen harmonics as well as THD have been mitigated below allowable levels considering only eight switching angles. Furthermore, the voltage THD has been kept in the determined value affected by unique pulses.

In following section, the hybrid SHM-SHE technique for four-leg NPC inverter has been explained. The new formulation of SHM-SHE using PAM concept is presented in section III. Theoretical results are illustrated and discussed in section IV. Finally, simulation and experimental results are provided in section V to confirm theoretical ones and to evaluate the performance of the proposed SHM-SHE-PAM switching technique.

II. HYBRID SHM-SHE PRINCIPLE FOR FOUR-LEG NPC INVERTER

Fig.1 illustrates the four-leg NPC inverter. The most important feature of this topology which makes it unique between all sorts of multilevel inverters is the special operation of the fourth leg (N). The fourth leg is connected to the same DC link like the other legs (A, B & C) and tied to the neutral point of the loads. The fourth leg can act as an output voltage balancer across the midpoint capacitors particularly when the loads are unbalanced. Due to the specific performance of leg N, its switching pattern must be distinguished from the phase legs.

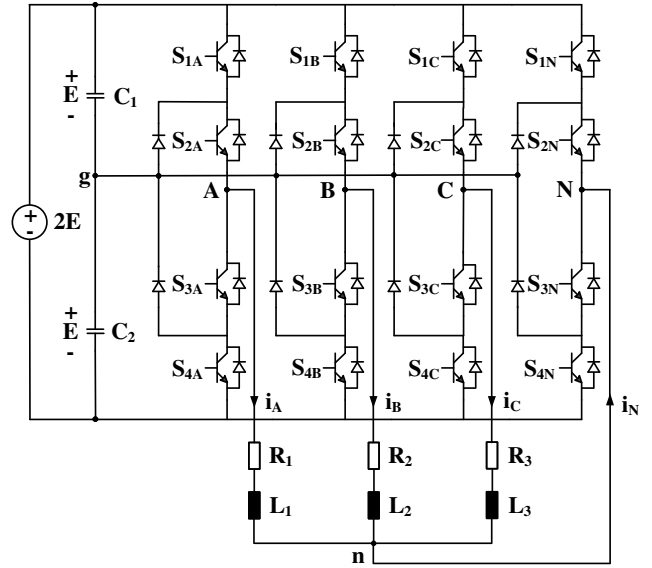

Fig. 1. Four-leg configuration of NPC inverter

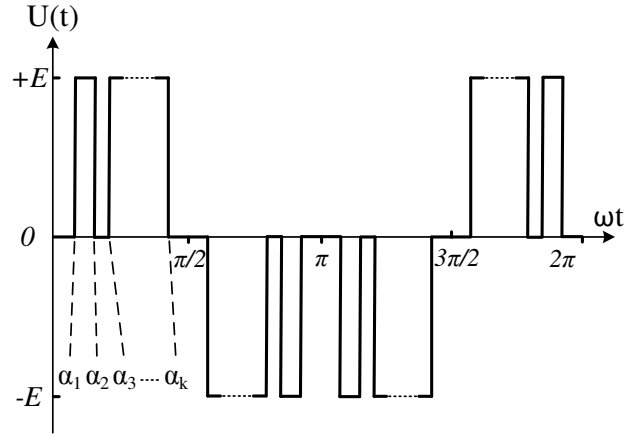

Fig. 2. Predefined three level branch voltage waveform

The SHE and SHM techniques are based on Fourier series analysis of three-level branch voltage waveform in NPC inverter. The branch voltage waveform is considered predefined as quarter-wave symmetrical waveform to eliminate the even order harmonics inherently. Fig. 2 shows a typical three level branch voltage waveform. Therefore, its Fourier series derived from the quarter-wave symmetric switching waveform can be written as:

$$V(t) = \sum_{n=1}^{\infty} H_n \cos(n\omega t) \quad \forall n = 1, 3, 5, 7, 9, 11, \dots \quad (1)$$

Where, H_n is the amplitude of n^{th} odd order harmonic and will be obtained with respect to the predetermined branch voltage waveform with the K pulses in the first quarter cycle shown in Fig. 2.

$$H_n = \frac{4E}{n\pi} \sum_{i=1}^k (-1)^i \sin(n\alpha_i) \quad \forall n = 1, 3, 5, 7, 9, 11, \dots \quad (2)$$

TABLE I
EN50160 AND CIGRE WG 36-05 REQUIREMENTS FOR
NON-TRIPLIN AND TRIPLIN HARMONICS AMPLITUDES

Non-Triplen Harmonics		Triplen Harmonics	
Harmonic order (n)	Maximum Allowable Level (L_n)	Harmonic order (n)	Maximum Allowable Level (L_n)
5	6%	3	5%
7	5%	9	1.5%
11	3.5%	15	0.5%
13	3%	21	0.5%
17	2%	>21	0.2%
19	1.5%		
23	1.5%		
25	1.5%		
>25	0.2+32.5/n		

The hybrid SHM-SHE equations for four-leg NPC inverter consists of two parts; leg A's SHM equations and Leg N's SHE equations. According to the SHM principle for leg A, switching angles ($\alpha_1, \alpha_2, \dots, \alpha_k$) are obtained to mitigate the amplitude of non-triplen low order harmonics below the limits imposed by the standards EN 50160 and CIGRE WG 36-05 [22, 23]. The grid code standard limits for odd harmonics amplitude used in [22, 23] are listed in table I. Moreover, at the same time, amplitude of the first harmonic must be set to the modulation index value (m_a). Hence, SHM equations for leg A are formulated as:

$$\begin{cases} F_1 = \frac{4E}{\pi} \sum_{i=1}^k (-1)^{i+1} \sin(\alpha_i) = m_a \\ F_n = \frac{4E}{n\pi} \sum_{i=1}^k (-1)^{i+1} \sin(n\alpha_i) \leq m_a L_n \\ \forall n = 5, 7, 11, \dots, 49 \\ 0 < \alpha_1 < \alpha_2 < \dots < \alpha_K < \frac{\pi}{2} \end{cases} \quad (3)$$

Since, SHM equations consider all non-triplen harmonics up to 49th, assuming K switching angles for leg A, at least $K-1$ non-triplen harmonics can be reduced under grid code limit. In SHM technique, more harmonics have chance to fulfill grid code limit (mitigate) at same switching frequency of SHE. However, in order to satisfy the harmonics mitigation according to the importance of harmonics order, the SHM equations need to be reformulated as an Objective Function (OF):

$$OF(\alpha_1, \dots, \alpha_K) = \sum_{n=1, 5, 7, \dots, 49} C_n (F_n)^2 + C_{THD} THD \quad (4)$$

restricted to $0 < \alpha_1 < \alpha_2 < \dots < \alpha_K < \frac{\pi}{2}$

Actually, by selecting appropriate coefficient for each F_n (C_n), OF provides a situation in which low order harmonics have more chance to be mitigated compared to the higher orders. To this end, the weighted penalty parameters coefficients C_n are defined in a non-linear way following the next general rules:

$$\begin{aligned} C_5, C_7, \dots, C_{3K-1} &\geq C_{3K+1}, \dots, C_{49} \quad \text{for even } K \\ C_5, C_7, \dots, C_{3K-2} &\geq C_{3K+2}, \dots, C_{49} \quad \text{for odd } K \end{aligned} \quad (5)$$

$$C_n = \begin{cases} C_n^h & F_n > L_n \cdot F_1 \\ C_n^l & F_n \leq L_n \cdot F_1 \end{cases}$$

where L_n are the considered grid code limit for n^{th} harmonic.

Also, the coefficient of voltage THD (C_{THD}) is assumed as a different value. C_{THD} can be selected to increase the chance of mitigating higher order harmonics. Therefore, switching angles of leg A are calculated directly solving OF ($\alpha_1, \alpha_2, \dots, \alpha_k$) by considering the proper coefficient for C_n and C_{THD} . Switching angles of leg B and C are achieved through shifting leg A's pulses by 120° .

Switching angles for the fourth leg are computed to eliminate low order triplen harmonic of leg A's voltage consistent with SHE principle. So, considering m switching angles for leg N's voltage waveform ($\beta_1, \beta_2, \dots, \beta_m$) and substituting them into (2), the Fourier series coefficient of leg N's branch voltage will be achieved. However, the fundamental frequency of fourth leg's branch voltage must be tripled as for phase legs to ensure that only triplen harmonics are generated. Then, SHE equations for leg N are obtained by equaling the amplitude of leg A's triplen harmonics to the amplitude of fourth leg's harmonics as the following relation:

$$\begin{cases} \frac{4E}{n\pi} \sum_{j=1}^m (-1)^j \sin(n\beta_j) = \frac{4E}{3n\pi} \sum_{i=1}^k (-1)^i \sin(3n\alpha_i) \\ \forall n = 1, 3, 5, \dots, 2m-1 \\ 0 < \beta_1 < \beta_2 < \dots < \beta_m < \frac{\pi}{2} \end{cases} \quad (6)$$

In (6), number of fourth leg's switching angles (m) is equal to the number of removable triplen harmonics which is related to the number of leg A's switching angles and can be attained as below:

$$m = \left\lceil \frac{k}{2} \right\rceil \quad (7)$$

Afterwards,, in accordance with the SHM-SHE-PWM that is presented in [21], eight switching angles for phase legs with four pulses for leg N have been adopted to mitigate 5th to 23rd non-triplen harmonics and to eliminate 3rd 9th 15th and 21st triplen harmonics.

III. PROPOSED SHM-SHE-PAM SWITCHING TECHNIQUE

A. Switching Principles

In the conventional SHM technique, only switching angles are assumed as degree of freedom where if more harmonics need to be mitigated, more pulses must be considered in the branch voltage. So, switching frequency would be increased and nonlinear equations become more complicated to solve. Moreover, the main problem associated with the conventional

SHM equations is that they should be solved for each value of m_a . This increases the volume and time of calculations as well as there is always possibility that no result or multiple results are obtained for some value of m_a .

The value of DC input voltage (E) that is assumed constant as 1 p.u in the conventional SHM can be considered as an additional degree of freedom. So, this will give more flexibility into the conventional SHM equations which means more harmonics have chance to reduce without increasing switching frequency. Furthermore, in this condition, the conventional SHM equations can be reformulated to simplify the complexity of calculations through omitting m_a from the equations. In other words, equations are solved for one time, so, the switching angles are found constant. As a result, the THD will be achieved constant for entire range of m_a due to the constant pulses as below:

$$\begin{aligned} THD &= \sqrt{\frac{\sum_{n=5,7,11,\dots} H_n^2}{H_1^2}} \\ &= \sqrt{\frac{\sum_{n=5,7,11,\dots} \left(\frac{1}{n} \sum_{i=1}^k (-1)^i \sin(n\alpha_i) \right)^2}{\left(\sum_{i=1}^k (-1)^i \sin(\alpha_i) \right)^2}} \end{aligned} \quad (8)$$

For this purpose, the value of DC input voltage must be determined as a ratio of m_a .

$$E = Am_a \quad (9)$$

So, by substituting (9) into the conventional SHM equations for leg A (Eq. (3)), the new SHM equation for phase legs is obtained.

$$\left\{ \begin{aligned} F_1^{new} &= A \sum_{i=1}^k (-1)^{i+1} \sin(\alpha_i) = \frac{\pi}{4} \\ F_n^{new} &= A \sum_{i=1}^k (-1)^{i+1} \sin(n\alpha_i) \leq \frac{n\pi}{4} L_n \\ \forall n &= 5, 7, 11, \dots, 49 \\ 0 &< \alpha_1 < \alpha_2 < \dots < \alpha_K < \frac{\pi}{2} \\ 0 &< A < 1 \end{aligned} \right. \quad (10)$$

It has been found that restricting A to values lower than 1 pu provides lower amplitudes for higher order harmonics. To find the switching angles and A (coefficient in Eq. (9)), a new objective function is defined as:

$$OF(\alpha_1, \dots, \alpha_K, A) = \sum_{n=1,5,7,\dots,49} C_n^{new} (F_n^{new})^2 + C_{THD}^{new} THD \quad (11)$$

where new weighted penalty parameters coefficients C_n^{new} are defined in a similar non-linear way as Eq. (5) but considering more harmonics to mitigate since with the proposed scheme more harmonics have the chance to fulfil the grid code limits.

Also, switching angles for leg N will be found using same equations for fourth leg (Eq. (6)). However, owing to the constant value for leg A's angles (α_i), the switching angles for leg N (β_i) will be constant, too.

B. DC Input Voltage Considerations

In the SHM-SHE-PWM, the main component of output voltage (the first harmonic that is equal to m_a) is made through finding appropriate angles while DC input voltage is assumed constant (1 p.u.). Differently, in proposed SHM-SHE-PAM, this component is made by computing accurate value of DC input voltage while switching angles are constant. However, some restriction should be taken into account for the DC input voltage variation. In this case, increasing or decreasing of DC input voltage should be limited to prevent from rising power losses and rated power semiconductor switches limits [26].

$$E_{\min} < E < E_{\max} \quad (13)$$

Moreover, the DC link capacitors voltage balancing has been mathematically surveyed in [21]. Similarly, due to voltage waveforms and switching pulses symmetry, the neutral point voltage would be balanced and DC capacitors would have identical voltages.

IV. THEORETICAL ANALYSIS AND DISCUSSION

In theoretical results, the amplitude of non-triplen and triplen harmonics as well as phase to phase voltage THD in SHM-SHE-PWM and SHM-SHE-PAM have been analysed. Since in SHM-SHE-PWM eight switching angles had been obtained for phase legs, two scenarios can be considered to choose number of variables for SHM-SHE-PAM in order to make a comparison between these two modulation techniques.

A. Case I: Identical degrees of freedom

In this case, numbers of variables (degrees of freedom) in the SHM-SHE-PAM and SHM-SHE-PWM equations are assumed identical. Therefore, the switching frequency would be lower in the proposed method than the previously reported one. So, seven switching angles in addition to DC input voltage have been considered as degrees of freedom to mitigate amplitude of non-triplen harmonics below 49th by solving $OF(\alpha_1, \alpha_2, \dots, \alpha_7, A)$.

B. Case II: Identical switching frequency

In this case, eight switching angles as well as DC input voltage have been considered in the objective function of SHM-SHE-PAM ($OF(\alpha_1, \alpha_2, \dots, \alpha_8, A)$). Consequently, the

switching frequency would be same in both techniques because of equivalent number of pulses. In fact, more non-triplen harmonics will be mitigated rather the previous case I.

Switching angles obtained for SHM-SHE-PAM method based on the above assumed cases are shown in table II.

TABLE II
CALCULATED RESULTS FOR SHM-SHE-PAM REGARDING CASE I & CASE II

Case I:	α_1	α_2	α_3	α_4	α_5	α_6	α_7	A	
	0.0449	0.0578	1.1706	1.2064	1.2804	1.3490	1.3851	0.834	
Case II:	α_1	α_2	α_3	α_4	α_5	α_6	α_7	α_8	A
	0.0036	1.1443	1.1647	1.2381	1.2781	1.3286	1.3912	1.4184	0.826

Fig. 3 depicts the worst value for non-triplen harmonics amplitude up to 49th and voltage THD in SHM-SHE-PWM and both cases of SHM-SHE-PAM. The worst case results have been found for the determined range of modulation index ($0.8 \leq m_a \leq 1.1$). This range of modulation index is enough for the UPS application to change the output voltage amplitude. In SHM-SHE-PWM, proportional to the number of angles for phase legs, the amplitudes of low order harmonics (5th to 23rd) are below standard level with respect to the maximum allowable level. However, for SHM-SHE-PAM case I; more non-triplen harmonics (5th to 31st) are mitigated appropriately. In addition, in SHM-SHE-PAM case II; all non-triplen harmonics amplitudes (5th to 49th) have been reduced below standard level. The above results prove the ability of proposed method to mitigate more harmonics in the same or even less switching frequency in comparison to the SHM-SHE-PWM.

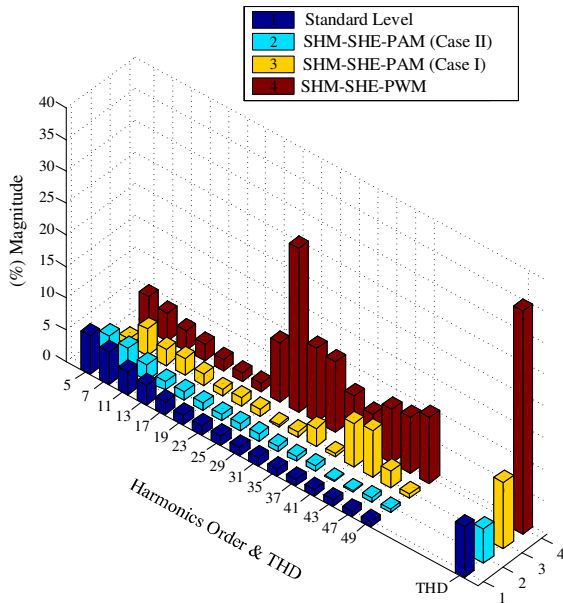

Fig. 3. The worst case results for non-triplen harmonics amplitude

In SHM-SHE-PWM, the worst case results are occurred in different modulation index. For example the worst value for amplitude of 25th harmonic is in $m_a=1.1$ and for 29th order is in $m_a=0.95$. However, in the SHM-SHE-PAM the worst case results for all amplitudes are obtained in the highest value of modulation index. It is due to the fact that in SHM-SHE-PAM

the modulation index is directly associated with the DC input voltage. Moreover, the phase to phase voltage THD has been reduced below standard level, as well. Fig. 4 shows the voltage THD in SHM-SHE-PWM and SHM-SHE-PAM in the whole range of modulation index (0.8 to 1.1). In which the constant value of line voltage THD for two cases are prominent. As a result, the superiority of the SHM-SHE-PAM technique shows that the four-leg NPC inverter requires significantly smaller filters than with SHM-SHE-PWM to provide a pure sine wave voltage at the output.

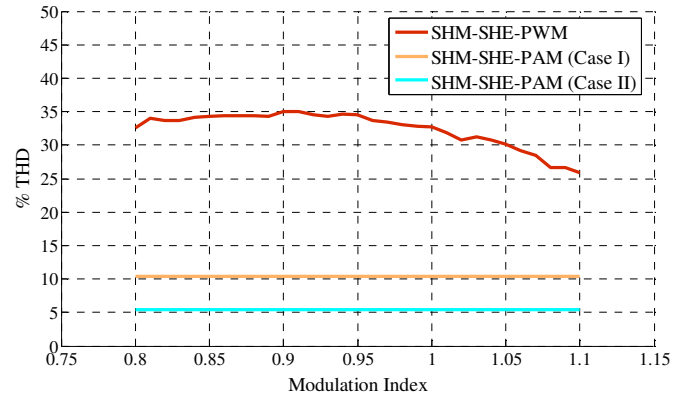

Fig. 4. The phase to phase voltage THD in SHM-SHE-PWM/PAM

As previously mentioned, triplen harmonics are removed from phase voltage by the fourth leg and switching angles are the only variables for this leg. Since, four switching angles had been engaged in the SHM-SHE-PWM to eliminate low order triplen harmonics, so in order to make a comparison, same number of pulses are used for leg N in both cases of SHM-SHE-PAM. Calculated switching angles for the fourth leg are shown in table III.

TABLE III
THE CONSTANT VALUE FOR FOURTH LEG'S SWITCHING ANGLES (RADIAN) IN SHM-SHE-PAM, CASE I & CASE II

Case I:	β_1	β_2	β_3	β_4
	0.1738	0.3462	0.7986	0.8718
Case II:	β_1	β_2	β_3	β_4
	0.1952	0.3642	0.8344	0.9155

Fig. 5 shows the triplen harmonics amplitudes of phase voltage in SHM-SHE-PWM and PAM. The triplen harmonics in the phase voltage is the result of difference between triplen harmonics of phase legs and neutral leg's branch voltage. As it is evident from that figure, the low order triplen harmonics including 3rd, 9th, 15th and 21st are completely eliminated in both SHM-SHE-PWM and PAM techniques. In fact, the lower triplen harmonics orders have the greatest effect on the DC link voltage balancing and consequently keeping the symmetry of output phase voltage waveform. In all the cases, triplen harmonics that are not compensated by means of the SHE leg modulation, have amplitudes greater than the standard limit; however, they are smaller in SHM-SHE-PAM compared to SHM-SHE-PWM. It is due to the fact that in SHM-SHE-PAM, phase legs generate triplen harmonics with smaller amplitudes.

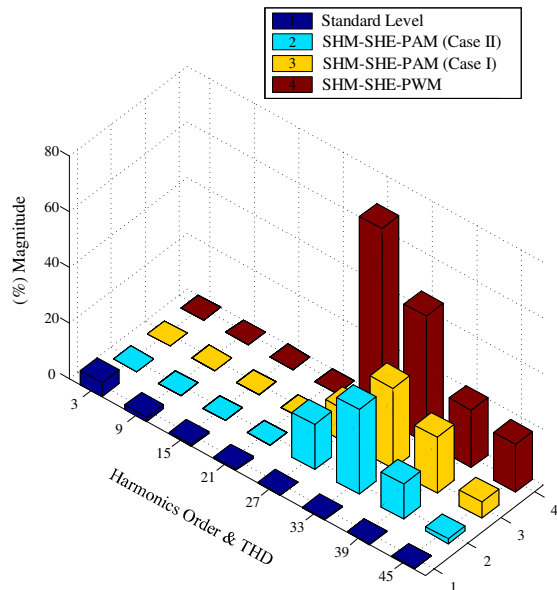

Fig. 5. The worst case results for triplen harmonics amplitude in SHM-SHE-PWM/PAM

V. SIMULATION AND EXPERIMENTAL INVESTIGATIONS

The SHM-SHE-PAM case II has been implemented on the four-leg NPC inverter due to the better harmonic content. The four-leg NPC prototype is built in the lab using SiC Mosfets switches to implement the proposed switching strategy. The prototype is controlled by real-time controller, dSpace 1103. The experimental parameters are listed in table II. The NPC is supplying different types of loads as UPS application.

TABLE IV

PARAMETERS USED IN THE FOUR-LEG NPC INVERTER PROTOTYPE

DC voltage source (V_{dc})	300 V
Frequency of output voltage for leg A	50 Hz
Frequency of output voltage for leg N	150 Hz
Load resistance	40 Ω
Load reactance	20 mH
Rectifier DC side load (R_{dc} , L_{dc}) as nonlinear load	40 Ω , 50 mH
DC- link capacitors (C_1, C_2)	650 μ F

Regarding the explained SHM-SHE-PAM technique, switching times are adjusted to be steady on one value for whole modulation index, while the DC input voltage is considered flexible to make the first component of output voltage. Hence, in order to provide desired DC input voltage, a DC-DC converter needs to feed DC side of the four-leg NPC inverter. The DC input voltage must be generated with respect to the modulation index value as it has been explained in Eq. (9). Fig. 6 shows the configuration of a UPS application for the four-leg NPC inverter.

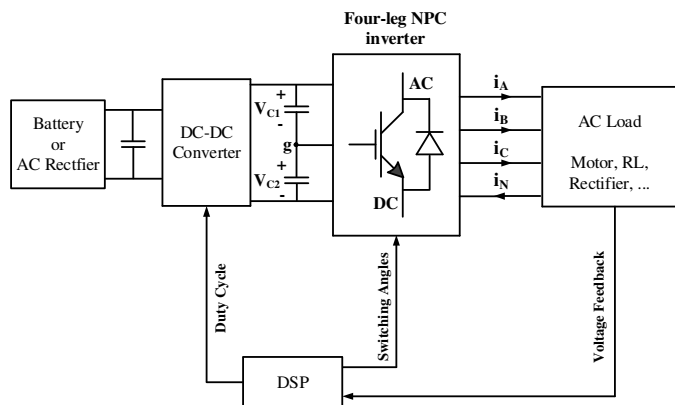
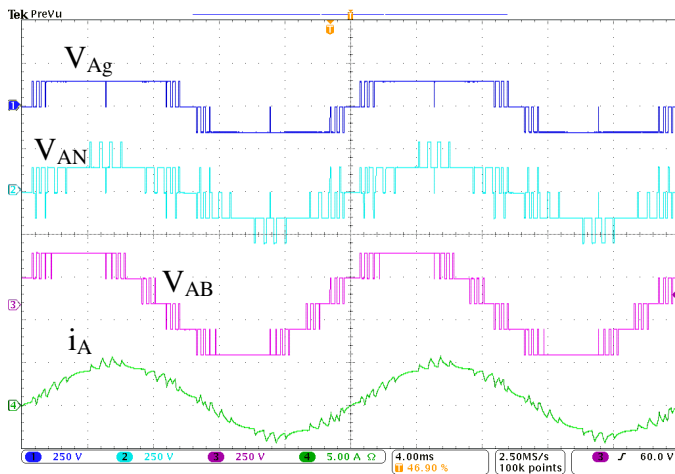

Fig. 6. The compatible configuration of four-leg NPC inverter to implement SHM-SHE-PAM

Fig. 7 shows steady state operation of the 3-phase 4-leg NPC inverter running by the proposed switching technique and supplying RL loads. Branch voltage (V_{Ag}), phase voltage (V_{AN}), line voltage (V_{AB}) and one phase current (i_A) are illustrated in Fig. 7-a as 3-phase operation. 400Hz switching frequency of phase legs switches is observable from the 3-level branch voltage waveform. Phase and line voltages waveforms include 5 levels which make them quasi sine wave with low harmonic content. Harmonic analysis of the phase and line voltages in experimental tests have been performed, which are normalized base on first amplitude harmonic. They have been illustrated in Fig. 7-b and 7-c; respectively, and have been compared with same simulation results and standard levels.



(a)

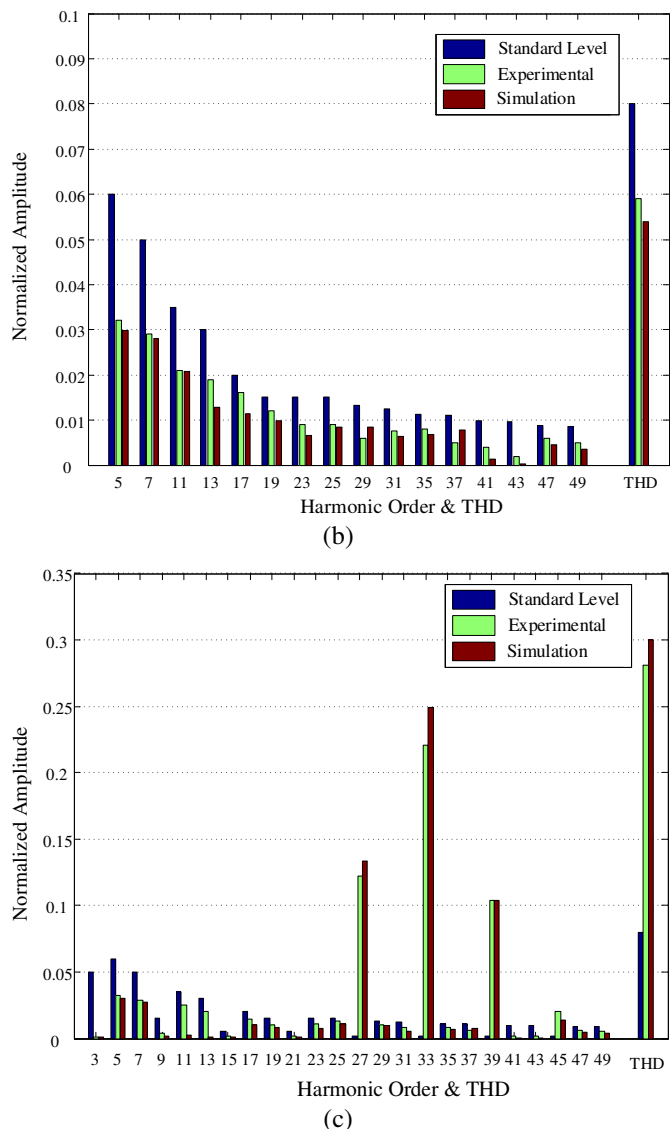

Fig. 7. Experimental results of the 4-leg NPC running by the SHM-SHE-PAM switching technique (a) output voltage and current waveforms (b) Harmonic spectrum of the output phase voltage (c) Harmonic spectrum of the output line voltage

In continue, unbalanced condition has been tested by adding a nonlinear load at the output of the running inverter. Fig. 8 shows results when the single phase rectifier is connected between leg A and B. Phase A current is increased while the capacitor voltage is balanced as was expected. However, the voltage ripple has been increased but still acceptable considering the small values of DC capacitors. Consequently, the output voltage waveform and harmonic content has not been affected even by a nonlinear unbalanced load.

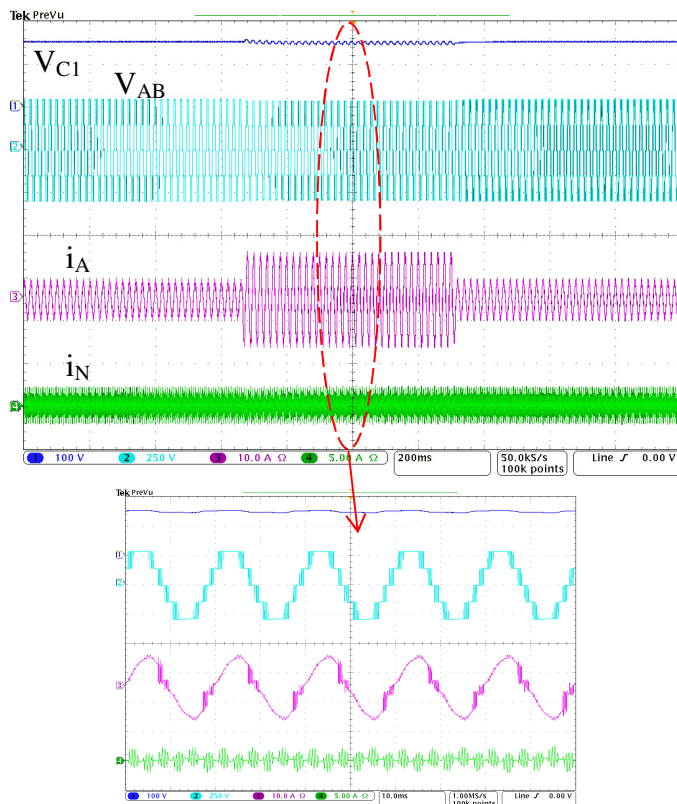

Fig. 8. Experimental results, when a single-phase diode rectifier (as a nonlinear load) is suddenly added at the output of the NPC inverter

VI. CONCLUSION

The general formulation for hybrid SHM-SHE-PAM technique has been presented in this paper. Consistent with SHM-SHE-PAM principle, both switching angles and DC input voltage have been assumed as degrees of freedom; however, the firing pulses for power switches are unique for all the modulation indexes range. Also, the DC voltage is obtained regarding to the modulation index in order to set the required amplitude of the voltage waveform fundamental component. So, compared to the SHM-SHE-PWM, the quality of output voltage in terms of the harmonic content has been significantly improved. In studied case, all the non-triplen harmonics up to 49th fulfilled the limits specified on grid codes EN50160:2010 and CIGRE WG 36-05 at a very low switching frequency of 400 Hz.. Furthermore, stabilization the voltage THD in specified value and the reduction in time and volume of calculations as well as the possibility of using simple hardware controller like AVR are the prominent advantages of PAM compared to PWM technique. Simulation and experimental tests have been carried out and shown results validate the ability of SHM-SHE-PAM switching strategy in driving the 4-leg inverter and eliminate/mitigate desired harmonics at the output. In addition, results confirmed that the presented modulation technique applied to 4-leg NPC inverter exhibits a good performance in terms of DC bus utilization since the modulation index can be set as high as 1.1. Therefore lower dc bus can be used, and consequently lower capacitor Farads/Volts ratings are requested for the same performance, consequently less costly power unit would be manufactured.

REFERENCES

- [1] J.-H. Kim, S.-K. Sul, and P. N. Enjeti, "A carrier-based PWM method with optimal switching sequence for a multilevel four-leg voltage-source inverter," *IEEE Trans. Ind. Appl.*, vol. 44, no. 4, pp. 1239-1248, 2008.
- [2] R. Portillo, S. Vazquez, J. I. Leon, M. M. Prats, and L. G. Franquelo, "Model based adaptive direct power control for three-level NPC converters," *IEEE Trans. Ind. Electron.*, vol. 9, no. 2, pp. 1148-1157, 2013.
- [3] V. Yaramasu, B. Wu, M. Rivera, and J. Rodriguez, "Predictive current control and DC-link capacitor voltages balancing for four-leg NPC inverters," in *IEEE International Symposium on Industrial Electronics (ISIE)*, 2013 2013, pp. 1-6.
- [4] N.-Y. Dai, M.-C. Wong, and Y.-D. Han, "Application of a three-level NPC inverter as a three-phase four-wire power quality compensator by generalized 3DSVM," *IEEE Trans. Power Electron.*, vol. 21, no. 2, pp. 440-449, 2006.
- [5] F. Rojas-Lobos, R. Kennel, and R. Cardenas-Dobson, "3D-SVM algorithm and capacitor voltage balancing in a 4-leg NPC converter operating under unbalanced and non-linear loads," in *Power Electronics and Applications (EPE), 2013 15th European Conference on*, 2013, pp. 1-10.
- [6] P. Lohia, M. K. Mishra, K. Karthikeyan, and K. Vasudevan, "A Minimally Switched Control Algorithm for Three-Phase Four-Leg VSI Topology to Compensate Unbalanced and Nonlinear Load," *IEEE Trans. Power Electron.*, vol. 23, no. 4, pp. 1935-1944, 2008.
- [7] H. Vahedi and K. Al-Haddad, "Real-Time Implementation of a Packed U-Cell Seven-Level Inverter with Low Switching Frequency Voltage Regulator," *IEEE Trans. Power Electron.*, vol. PP, no. 99, pp. 1-1, 2015.
- [8] H. Vahedi, P. Labbe, and K. Al-Haddad, "Sensor-Less Five-Level Packed U-Cell (PUC5) Inverter Operating in Stand-Alone and Grid-Connected Modes," *IEEE Trans. Ind. Informat.*, vol. 12, no. 1, pp. 361-370, 2016.
- [9] C. Buccella, C. Cecati, M. Cimatorini, and K. Razi, "Analytical Method for Pattern Generation in Five Levels Cascaded H-bridge Inverter using Selective Harmonics Elimination," *IEEE Trans. Ind. Electron.*, vol. 61, no. 11, pp. 5811-5819, 2014.
- [10] M. S. Dahidah, G. Konstantinou, and V. G. Agelidis, "A Review of Multilevel Selective Harmonic Elimination PWM: Formulations, Solving Algorithms, Implementation and Applications," *IEEE Trans. Power Electron.*, vol. 30, no. 8, pp. 4091-4106, 2015.
- [11] J. Napoles, J. I. Leon, R. Portillo, L. G. Franquelo, and M. A. Aguirre, "Selective harmonic mitigation technique for high-power converters," *IEEE Trans. Ind. Electron.*, vol. 57, no. 7, pp. 2315-2323, 2010.
- [12] J. Napoles, A. J. Watson, J. J. Padilla, J. I. Leon, L. G. Franquelo, P. W. Wheeler, and M. A. Aguirre, "Selective harmonic mitigation technique for cascaded H-bridge converters with nonequal DC link voltages," *IEEE Trans. Ind. Electron.*, vol. 60, no. 5, pp. 1963-1971, 2013.
- [13] M. S. Dahidah and V. G. Agelidis, "Selective harmonic elimination PWM control for cascaded multilevel voltage source converters: A generalized formula," *IEEE Trans. Power Electron.*, vol. 23, no. 4, pp. 1620-1630, 2008.
- [14] W. Fei, X. Ruan, and B. Wu, "A generalized formulation of quarter-wave symmetry SHE-PWM problems for multilevel inverters," *IEEE Trans. Power Electron.*, vol. 24, no. 7, pp. 1758-1766, 2009.
- [15] J. Leon, S. Kouro, L. G. Franquelo, J. Rodriguez, and B. Wu, "The Essential Role and the Continuous Evolution of Modulation Techniques for Voltage Source Inverters in Past, Present and Future Power Electronics," *IEEE Trans. Ind. Electron.*, vol. PP, no. 99, pp. 1-1, 2016.
- [16] F. Zhang and Y. Yan, "Selective harmonic elimination PWM control scheme on a three-phase four-leg voltage source inverter," *IEEE Trans. Power Electron.*, vol. 24, no. 7, pp. 1682-1689, 2009.
- [17] M. Sharifzade, H. Vahedi, A. Sheikholeslami, H. Ghoreishy, and K. Al-Haddad, "Selective harmonic elimination modulation technique applied on four-leg NPC," in *IEEE 23rd International Symposium on Industrial Electronics (ISIE)*, 2014, 2014, pp. 2167-2172.
- [18] M. Sharifzade, H. Vahedi, A. Sheikholeslami, H. Ghoreyshy, and K. Al-Haddad, "Modified selective harmonic elimination employed in four-leg NPC inverters," in *Industrial Electronics Society, IECON 2014-40th Annual Conference of the IEEE*, 2014, pp. 5196-5201.
- [19] M. Sharifzadeh, A. Sheikholeslami, H. Vahedi, P.-A. Labbé, and K. Al-Haddad, "Optimized Harmonic Elimination Modulation Extended to Four-Leg NPC Inverter," *IET Power Electron.*, 2015.
- [20] L. G. Franquelo, J. Napoles, R. P. Guisado, J. I. León, and M. A. Aguirre, "A flexible selective harmonic mitigation technique to meet grid codes in three-level PWM converters," *IEEE Trans. Ind. Electron.*, vol. 54, no. 6, pp. 3022-3029, 2007.
- [21] M. Sharifzadeh, H. Vahedi, A. Sheikholeslami, P.-A. Labbé, and K. Al-Haddad, "Hybrid SHM-SHE Modulation Technique for Four-Leg NPC Inverter with DC Capacitors Self-Voltage-Balancing," *IEEE Trans. Ind. Electron.*, vol. 62, no. 8, pp. 4890-4899, 2015.
- [22] "Voltage characteristics of electricity supplied by public distribution systems," *Std. EN 50160*, 2001.
- [23] "Harmonics, characteristic parameters, methods of study, estimates of existing values in the network," *Electra no 77, CIGRE WG 36-05*, pp. 35-54, 1981.
- [24] H. Ghoreishy, A. Varjani, S. Farhangi, and M. Mohamadian, "Hybrid cascaded H-bridge inverter with even power distribution and improved total harmonic distortion: analysis and experimental validation," *IET Power Electronics*, vol. 5, no. 8, pp. 1245-1253, 2012.
- [25] J. Pontt, J. Rodriguez, R. Huerta, and J. Pavez, "A mitigation method for non-eliminated harmonics of SHEPWM three-level multipulse three-phase active front end converter," in *IEEE International Symposium on Industrial Electronics (ISIE)*, 2003. , 2003, pp. 258-263.
- [26] L. K. Haw, M. S. Dahidah, and H. A. Almurib, "SHE-PWM cascaded multilevel inverter with adjustable DC voltage levels control for STATCOM applications," *IEEE Trans. Power Electron.*, vol. 29, no. 12, pp. 6433 - 6444, 2014.



Mohammad Sharifzadeh was born in Sari, Iran in 1989. He received the B.Sc. degree in power electrical engineering from Babol Noshirvani University of Technology (NIT), Babol, Iran in 2012, where he is currently pursuing his M.Sc. degree in power electrical engineering.

His research interests include power electronics multilevel converters; topologies and their switching techniques especially Selective Harmonic Elimination/Mitigation technique as well as optimization methods applications in power system.



Hani Vahedi (S'10) was born in Sari, IRAN, in 1986. He received his B.Sc. and M.Sc. degrees both in electrical engineering from K. N. Toosi University of Technology (KNTU), Tehran, IRAN in 2008 and Babol University of Technology, Babol, IRAN in 2011, respectively.

He is currently pursuing his PhD at the École de Technologie Supérieure (ÉTS), University of Quebec, in Montreal, Canada, as a member of Groupe de Recherche en Électronique de Puissance et Commande Industrielle (GRÉPCI). He is an active member of IEEE Industrial Electronics Society and its Student Forum. His research interests include power electronics multilevel converters topology, control and modulation techniques, power quality, active power filter, and their applications into smart grid, renewable energy conversion, UPS, battery chargers and electric vehicles.



Ramon Portillo (S'03-M'06) was born in Sevilla, Spain. He received the M.Sc and Ph.D. in electrical engineering from the Universidad de Sevilla, Seville, Spain, in 2003 and 2012 respectively. Since 2003, he has been Assistant Professor with the Department of Electronic Engineering (Universidad de Sevilla).

His research interests include power electronic systems, modulation and control of power electronic converters, renewable energy applications and aerospace power electronics applications. He was recipient as co-author of the 2008 Best Paper Award of the IEEE Industrial Electronics Magazine and the 2012 Best Paper Award of the IEEE Transactions on Industrial Electronics.



Mohammad Khenar was born in Qaemshahr, Iran, in 1988. He received the B.Eng. and M.Eng. degrees from Babol Noshirvani University of Technology (NIT), Babol, Iran, in 2011 and 2014, respectively.

His current research interests include design and control of power electronics converters, pulse width modulation strategies, power quality and control of renewable energies interfacing to the grid and transmission line (especially multi-terminal HVDC transmission lines).



Abdolreza Sheikholeslami was born in Iran. He received the B.Sc. (Hons.) degree from Mazandaran University, Babolsar, Iran, and the M.Sc. and Ph.D. degrees from the University of Strathclyde, Glasgow, U.K., in 1978 and 1989, respectively. He has been an Associate Professor with the Department of Electrical and Computer

Engineering, Noshirvani University, Babol, Iran, since 2009. His current research interests include power electronic, power quality, harmonics, smart grids, and renewable energy.



Leopoldo G. Franquelo (M'84-SM'96-F'05) was born in M'álaga, Spain. He received the M.Sc. and Ph.D. degrees in electrical engineering from the Universidad de Sevilla, Seville, Spain in 1977 and 1980 respectively.

Dr. Franquelo has been a Industrial Electronics Society (IES) Distinguished Lecturer since 2006, an Associate Editor for the IEEE Transactions on Industrial Electronics since 2007, Co-Editor-in-Chief since 2014, and Editor-in-Chief since 2015. He was a Member-at-Large of the IES AdCom (2002-2003), the Vice President for Conferences (2004-2007), and the President Elect of the IES (2008-2009). He was the President of the IEEE Industrial Electronics Society (2010-2011) and currently is IES AdCom Life member. His current research interest lies on modulation techniques for multilevel inverters and its application to power electronic systems for renewable energy systems.

He has received a number of best paper awards from journals of the IEEE. In 2012 and 2015 he received the Eugene Mittelmann Award and the Antohny J. Hornfeck Service Award from IES respectively.



Kamal Al-Haddad (S'82-M'88-SM'92-F'07) received the B.Sc.A. and M.Sc.A. degrees from the University of Québec à Trois-Rivières, Canada, in 1982 and 1984, respectively, and the Ph.D. degree from the Institute National Polytechnique, Toulouse, France, in 1988. Since June 1990, he has been a Professor with the

Electrical Engineering Department, École de Technologie Supérieure (ETS), Montreal, QC, where he has been the holder of the Canada Research Chair in Electric Energy Conversion and Power Electronics since 2002. He has supervised more than 100 Ph.D. and M.Sc.A. students working in the field of power electronics. He is a Consultant and has established very solid link with many Canadian industries working in the field of power electronics, electric transportation, aeronautics, and telecommunications. He has coauthored more than 500 transactions and conference papers. His fields of interest are in high efficient static power converters, harmonics and reactive power control using hybrid filters, switch mode and resonant converters including the modeling, control, and development of prototypes for various industrial applications in electric traction, renewable energy, power supplies for drives, telecommunication, etc. Prof. Al-Haddad is a fellow member of the Canadian Academy of Engineering. He is IEEE IES President 2016-2017, Associate editor of the Transactions on Industrial Informatics, IES Distinguished Lecturer and recipient of the Dr.-Ing. Eugene Mittelmann Achievement Award.