

Fault diagnosis decentralized of manufacturing systems using Boolean models

Hireche Slimane¹, Mohamed Habbab¹, Abdeldjebar Hazzab^{1,2,3}, Ahmed Khalil Moussaoui¹,
Ambrish Chandra³, Hicham Gouabi^{1,2,3}, Alhachemi Moulay Abdellah¹

¹Laboratory of Command, Analysis and Optimization of Electro-Energetic Systems (CAOSEE), Tahri Mohamed University, Bechar, Algeria

²Energy Intelligence Research and Innovation Center (CR2ie) Cégep de Sept-Îles, Québec, Canada

³Department of Electrical Engineering, École de Technologie Supérieure, Montréal, Canada

Article Info

Article history:

Received Dec 25, 2023

Revised Jul 10, 2024

Accepted Jul 24, 2024

Keywords:

Automata

Boolean modelling

Diagnosis decentralized

Discrete event systems

Manufacturing systems

ABSTRACT

This paper introduces an approach decentralized to fault detection and isolation (FDI) in manufacturing systems using a Boolean discrete event model. The method incorporates diverse information sources to create distinct models for plant systems and control. The objective is to enhance the understanding of process operations by employing various representation tools tailored to each information source. It is to reduce the number of explosion problems combinatorial and detect faults in the shortest possible time. This comprehensive representation facilitates the fulfillment of three crucial diagnosis functions: detection, localization, and identification. The approach involves Boolean modeling of each process actuator along with its corresponding sensors, a temporal model based on fuzzy expectations of event occurrences, and a set of if...then rules. The goal of this decentralized approach minimize both the complexity and the manual construction effort required for the model. The paper demonstrates the effectiveness of this approach through an illustrative example involving manufacturing systems.

This is an open access article under the [CC BY-SA](https://creativecommons.org/licenses/by-sa/4.0/) license.



Corresponding Author:

Hireche Slimane

Laboratory of Command, Analysis and Optimization of Electro-Energetic systems (CAOSEE)

Tahri Mohamed University

Béchar, Algeria

Email: etn.sliman@gmail.com

1. INTRODUCTION

Industrial systems may encounter faults that can disrupt their anticipated functioning, resulting in diminished performance and potential equipment damage. Numerous studies in the literature tackle the challenge of diagnosing faults in discrete-event systems (DESs) represented through automata or Petri nets [1]. Some recent studies [2], [3] have suggested that the centralized diagnosis structure has some drawbacks, So this method consists of associating a global model of the process with a single diagnostic module, which we call "diagnosticator". The latter collects the various information of the process before making a final decision on the state of operation of the process. Although efficient in terms of diagnosis, the centralized structure is difficult to use for large systems. In fact, the constitution of a global model of the process very often generates explosion problems combinatorial.

The predominant gain of techniques [4], [5] using both normal and fault behaviors, is the precision of the fault isolation. However, integrating the system behavior in response to a predefined set of faults increases significantly the model size. More than that, only predefined faults can be diagnosed. These disadvantages can be avoided using Boolean models. It is not realistic to use a global model to identify a large discrete event

system (DES). Moreover, such policies are inherently decentralized [6], [7]. They consist of many subsystems or components that carry their own local information. Another way to identify these systems is through methods of spatial assignment or distribution. Among geographically diverse methods, the diagnosis is based on a number of local examinations. Each local survey is responsible for a restricted portion of the program. Because no correlation is allowed between local probes, a global model of the system is needed to capture the correlation between components. Distributed methods do not require a global model. The latter are illustrated by some local examples. Each local instance knows only its own actions. Connections, or dependencies, between components are achieved through transitions between local analyzes using networks or through integration processes and integration is achieved through a sequence of component-oriented actions species local assessment or the extension of concepts from local assessments to its neighbors

The development of local diagnosers relies on a modular modeling approach encompassing plant elements, controller specifications, and temporal information regarding actuator reactivity [8]. The most important characteristics waited of an automated diagnosis are, the diagnosis must be easy to develop, it must be easy to implement and must be achieved with a minimum number of sensors. This methodology can be regarded as a distinctive instance of an observer, where fault information is conveyed through labels affixed to states. Diagnosers make decisions based on the sequences of observed events.

In this article, we proposed a method based on a decentralized fault-free model to diagnose plant faults in DESs. To define a global model, the independence between components of the system is implemented by error-free instances of its components. Each component consists of an actuator and associated sensors. This model is represented as a Boolean DES model. Any behavior that is not consistent with normality is considered error behavior. The component elements (actuators/sensors) that cause this fault behavior are considered fault candidates [9]. The paper illustrates the effectiveness of this approach through a case study involving manufacturing systems [10]. To exemplify these innovative concepts, we intended to test them in a practical scenario involving the transfer of parts from a magazine.

2. DIAGNOSIS METHODS

There are various approaches to design and develop an automated diagnostic system [11], [12]. The selection of a specific approach depends on various parameters, including the dynamics of the system (hybrid discrete or continuous), the implementation perspective 1 or 0, the representation of information (qualitative or quantitative), the complexity of the system large or simple. In this context, our emphasis is on fault diagnosis methods specifically tailored for manufacturing systems [13], [14]. We have just seen the different criteria for diagnostic methods taken from the literature. This study allows us to justify our choices in the diagnostic approach that we have developed. Table 1 presents the comparison between fault diagnosis centralized and decentralized approaches

Table 1. Comparison between fault diagnosis centralized and decentralized approaches

The different criteria of the methods of diagnosis systems	Decentralized approaches	Centralized approaches
Modeling tools	State automata: accurate description, language theory, and composition tools.	Petri net: distribution of elements risk of explosion
Models of defaults	Mixed and state base: fault detection intermittent and fault in initialization	Based on events: breakdowns intermittent.
Structure of taking decision	With coordinator: minimize combinatory explosion and management conflict by a coordinator	Without a coordinator: no communication and a combinatory explosion

2.1. Model-based local diagnostics approach

2.1.1. System automate using Boolean models

In our approach, we make use of Boolean discrete event systems (BDES) modeling, as introduced in previous study [15], to capture the behavior of system equipment, including actuators and sensors. We propose a model-based approach to diagnose discrete event systems (DES). Building a mathematical model G is crucial for defining how system states evolve in response to event occurrences. This model follows a decentralized structure, where the system is composed of several local components (G_i , $i = 1..n$), each coordinated to minimize communication. The diagnostic model is distributed, with multiple local diagnostics (D_i , $i = 1..n$) typically assigned to specific local components. The decentralized and distributed nature aims to alleviate the space explosion problem during the design phase and make it easier to locate faulty elements. This modular approach exploits the structure of the system using different representation tools such as automata, rules, Boolean and mathematical equations, depending on the available information. Three key models are defined in this approach: the factory, control and diagnostic models [16], [17].

a) Plant element

Communication between local diagnoser is employed to fine-tune local diagnoser. Nevertheless, the primary drawback is the requirement to establish an effective communication protocol. In the multi-model approach, the plant model is divided into several components, each dedicated to an actuator [18]. Each G_i model and its corresponding language L_i delineate the logical and untimed behavior of the monitored system as in (1).

$$G_i = (M, \Sigma c) \quad (1)$$

M is a Moore automate represented in (2).

$$M = (\Sigma, Y, \delta, h) \quad (2)$$

Σ is the set of finite events, Y is the output space, X is the set of normal states.

$$\delta: \Sigma \times X \rightarrow X \quad (3)$$

The (3) is the state transition function. $\delta(\sigma, q)$ gives the set of possible next states if σ occurs at q .

$$h: \Sigma \times X \rightarrow Y \quad (4)$$

$H(\sigma, x)$ is the observed output when σ occurs at x , in (4) represents output function [19], [20]. While in (5) represents define controllable events:

$$EC = (\Sigma c \subseteq \Sigma) \quad (5)$$

Controllable event is actuators as the control outputs, while (6) uncontrollable events are:

$$EU = (\Sigma u \subseteq \Sigma) \quad (6)$$

The (7) is sensors are defined as the control inputs:

$$IC = (\Sigma o \subseteq \Sigma) \quad (7)$$

While (8) is the set of observable events where:

$$EO = (\Sigma c \subset \Sigma o) \quad (8)$$

An automaton is employed for each model. This automaton considers all observable events. The detailed explanation of the construction of this model can be found in study of Debouk *et al.* [21]. Each of these automata is represented by an input/output vector $(\Sigma u, \Sigma c)$ called the plant table, PT_i , for actuator i . All vectors not represented by the PT_i correspond to logical inconsistencies resulting from sensor failures [22].

b) Control manufacturing systems

The system model is developed using a GRAFCET or Petri net. This graphical representation encapsulates the functional information corresponding to the scheduling conditions for all system components. GRAFCET is chosen as the modeling tool for the controller due to its widespread adaptation in industrial applications, particularly in manufacturing systems [23], [24].

c) Diagnoser models

Diagnosers are obtained by intersection between plant models and control models. This intersection leads to a functional automaton describing the normal behavior for each actuator [25]. Each functional automaton, diagnose model, is represented in a second table and is called control plant table of the actuator i (CPT $_i$). Each CPT $_i$ can detect all abnormal behaviors of the control. Since these diagnosers are decentralized, the detection and the isolation of failures can be realized in a modular manner. For each order, the diagnoser compares the CPT $_i$ output with the real situation. The steps of functionality of each diagnoser are organized as [26], [27]: i) definition of event actuator of the CPT $_i$, ii) Binary code of the events of CPT $_i$, iii) affectation of weight for each event, iv) initialization of the CPT $_i$ with the real situation of the process, v) evolution of the CPT $_i$ when an event arrives, vi) comparison of the code decimal table (codec) with the current situation (sitc), vii) failure is detected when an evolution of the cpti is not corresponding to the current situation, viii) failure isolation by Boolean operator “exclusive or” between the latest correct situation and the current one; and ix) Identification with event historic and expert analyze when a failure is detected, step 8, an alarm is enabled and diagnosers search to isolate it. an event historic can be used to define the last correct state. the Boolean operator “exclusive or” permits to know the sensor or the actuator in fault.

d) Symbolic information

Expert information can provide valuable information about process functioning and work conditions under the form of rules. Personal security or quality constraints can be also provided by experts [28], [29]. Moreover, these rules can be used as a coordinator for realizing a minimum of communication between the different plant models [30].

3. MANUFACTURING SYSTEM

To illustrate the proposed method, we use an example of a two-cylinder machine used to transport parts from the magazine to the chute as seen in Figure 1. Once the push button is pressed, the first cylinder A is extended, the part is pushed out of the magazine and the second cylinder B is positioned on the outfeed chute in preparation for transfer (Pi: parts in front of pusher A and B). when the part is moved, the first cylinder stops, and the second follows. Both extended and retracted positions should be emphasized (Pe: partially omitted) cylinder A and B advancing step is designated as (A+, B+), cylinder A and B retracting step is designated as (A-, B-).

3.1. Cylinder plant model

To construct the cylinder plant table as revealed in Table 2, we use the input/output (n) interpretation. Here, there are two controllable events (B+ and B-) and two uncontrollable events corresponding to the sensor's outputs b1 and b0. The plant table contains 2^n possible ones as revealed in Table 2. In this context, we are not concerned with logic inconsistencies (3, 7, 11, 15) as can be seen in Table 3, associated with controllable events but rather those related to uncontrollable events (non-controllable) because only the inputs of the part are taken into consideration [31]. The goal is to eliminate logical inconsistencies among inputs.

The construction of the equivalent automata is carried out from the diagram of controllable evolutions. This diagram is derived from the truth table representing the system after removing logical inconsistencies. For each combination, the occurrence of a controllable event enables the alteration of the output state, leading to a new state. Supplement of the automata with the non-evolving controllable. This involves using rules of occurrence and precedence relationships as well as the initial conditions.

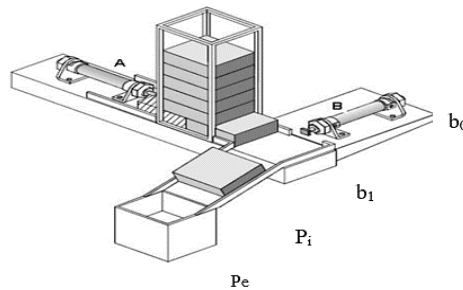

Figure 1. Transfer parts from a magazine

Table 2. Cylinder plant table

States	B+	B-	b1	b0	States	B+	B-	b1	b0
0	0	0	0	0	3	0	0	1	1
1	0	0	0	1	4	0	1	0	0
2	0	0	1	0	5	0	1	0	1

Table 3. Diagram of developments

b1b0	B+	B-	00	01	11	10
00	0	1	2			
01	4	5	6			
11	12	13	14			
10	8	9	10			

For the movement of the cylinder B, the first step consists in set the 24 combinations between advancer (B+), recline (B-), b1 and b0 as can be seen in Table 2. The second step is to remove. The four logical inconsistencies of events related to the fact that b1 and b0 can not be true at the same time. The automata of evolutions is then determined from the diagram of the controllable evolutions thus expressing all the possible evolutions between the states as in Figure 2. These evolutions are defined only by events controllable: ↑ B+, ↓ B+, ↑ B-, ↓ B-. Knowing that B+, B-, can either take the value 1 for activation or 0 for the deactivation Figure 2. The precedence relations in the last step, the final automata presented Figure 3. From the initial state (2), an event possible outgoing is ↑ B+. His occurrence leads to state 10. According to Table 1, the consequence of B is the appearance of the event non-controllable ↓ b1, which makes it possible to reach state 8. The other non-controllable developments are added to the base controller in the same way. This method of modeling is applied

to each of the parts of the system. The complete model of the operative part is then obtained by the asynchronous composition of all the elementary models. For the example, the automata of the complete operative part obtained by the asynchronous product of the elementary models composed of 144 states.

3.2. Diagnoser models

Diagnosers are derived using the plant models and the control model Figure 3. The control system is depicted by the GRAFCET, and it illustrates the diagnoser models of actuator A and the simple effect cylinder B according to the GRAFCET in Figure 4. These models are obtained through the intersection between the controller (GRAFCET) and the plant model of each actuator.

3.3. Symbolic information on the system

Experts give their own constraints about the global system. These constraints are expressed by rules. As an example, if a constraint is to keep the cylinder in the a_1 position when the cylinder B is not in the b_1 position, then the rule is expressed as (9). Then default, others functions can be established in the same manner by expert.

$$\text{If } (B1=1 \text{ or } B0=1 \text{ or } P2=1) \text{ and } a1=0 \tag{9}$$

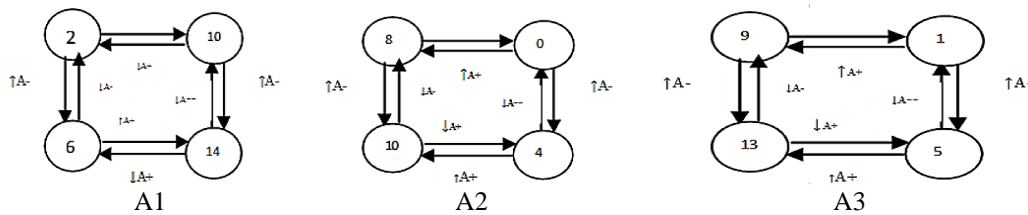

Figure 2. Complete automata

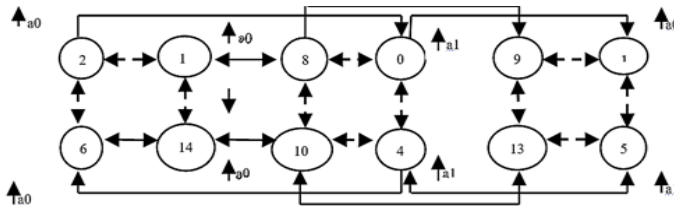

Figure 3. Automata without non controllable evolution the plant model of cylinder

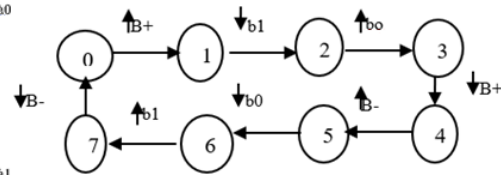

Figure 4. Diagnosers models controller GRAFCET

3.4. Detection, isolation and identification

For the cylinder, the first step is to define in (10) the actuator events.

$$\Sigma_1 = \{ \uparrow A_0, \downarrow A_0, \uparrow A_1, \downarrow A_1, \uparrow a_0, \downarrow a_0, \uparrow a_1, \downarrow a_1 \} \tag{10}$$

Then, a binary code is assigned to the control plant table of the cylinder, CPT_{cy} , as in Table 4. The latter is constructed in using the diagnoser model in Figure 2. Initially, the cylinder is in A_1 ($Sitc=8$) which is corresponding to the first line of the table (codec=8). Each event of the cylinder entails the change of the CPT_{cy} line as well as for the weight of the current situation. For the cylinder, when the a_1 order is sent, the position indicator of the cylinder goes a_1 to second line which correspond to codec = 10. Current situation has a new weight of $Sitc$ defined in (11).

$$Sitc = Sitc - 1 + 2 = 8 + 2 = 10 \tag{11}$$

Code table and current situation are matched thus no failure is declared. If a non-awaited event is generated, as an example the occurrence of $\uparrow A_0$ when the cylinder is going down, then the current situation is defined in (12).

$$Sitc = Sitc - 1 + 4 = 10 + 4 = 14 \tag{12}$$

The code table is codec = 2. The comparison permits to detect an observable failure the vector of general in (13). To isolate it, Si $sitc=1110$ and $Sitc - 1 = 0110$ represented in (14), the current situation as shown in

(15) is compared between $sitc$ and $Sitc - 1$ using the Boolean operator “exclu or” the vector of general to obtain the result in the last in (16).

$$A=(A_1A_0a_1a_0) \tag{13}$$

Si

$$\begin{cases} sitc = 1110 \\ Sitc - 1 = 0110 \end{cases} \tag{14}$$

Then,

$$A=sitc \oplus sitc_{-1} \tag{15}$$

$$A=1000 \tag{16}$$

Sensor Boolean operator A_1 in default.

Table 4. Binary code of the cylinder CPT

A1	A0	a1	a0	Codec	A1	A0	a1	a0	Codec
1	0	0	0	8	0	1	0	0	4
1	0	1	0	10	0	1	0	1	5
0	0	1	0	2	0	0	0	0	1
0	1	1	0	6	1	0	0	1	9

3.5. The coordinator

Each local diagnoser makes its decision locally and informs the operator through the value of the current status prediction function, event history, state vector, and last element part operative (EPO) event. All that remains is to express the overall process specifications that cannot be described by the local diagnostic agents. It is the interactions between elements that must be established through rules in the coordinator.

4. RESULTS OF THE SIMULATION

The simulation must include the two local diagnosticians as well as the coordinator expressing the global constraints of the system. Figure 5 shows the simulation using Stateflow of transfer parts. It presents two diagnostics corresponding to the two elements of the system which are the cylinder A and B. To simulate the behavior of the PC and the PO, we have placed two modules allowing the simulation of the inputs/outputs of the elements. The local diagnosticians return, to the coordinator's decision table, their decision via fault labels as well as the label corresponding to the forecast function. The aggregation of all the local decisions and the coordinator's rules then makes it possible to make a final decision on the behavior of the system to the user.

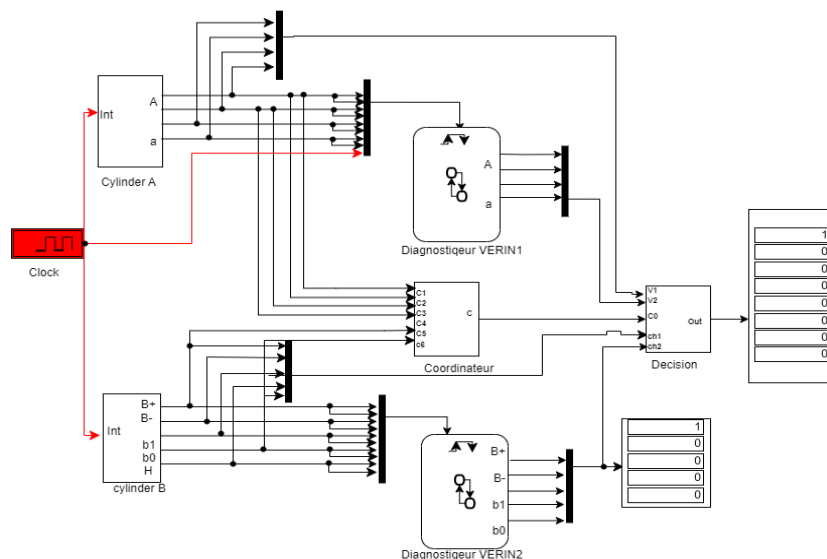

Figure 5. Block Simulink using Stateflow

4.1. Local cylinder diagnostic

Figure 6 presents the simplified diagnostician. A for unobservable faults where the initial state is represented by an arrow with a point. Stateflow, not managing the symbols ↓ and ↑, the rising edge of an event is represented by the letters "fm" in front of the event while the falling edge is described by the letters "fd" and SO represents the cylinder output A (A1) and RE instead of A0.

4.2. The coordinator

The coordinator must also retrieve all of the local decisions in order to make a final decision to the user. For this, we created a decision aggregation module collecting all the fault labels from local diagnosticians corresponding to either an observable fault. the final decision is obtained by a logical "1" next to each label, corresponding to a fault that has occurred. The different fault partitions are recalled in Table 5.

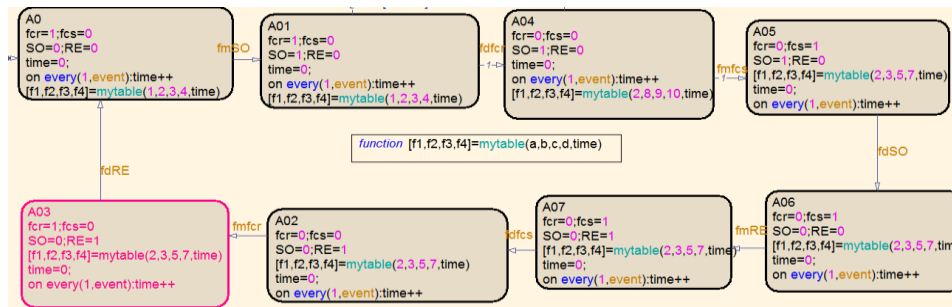

Figure 6. Cylinder diagnostician by Stateflow

Table 5. Fault matrix of the cylinder

		Etat										Etat							
Default		x1	X2	X3	X4	X5	X6	X7	X8	Default		x1	X2	X3	X4	X5	X6	X7	X8
F1	f1	1	1	0	0	0	0	1	1	F4	f7	1	1	1	1	1	1	1	1
	f2	0	1	1	1	1	1	1	0		f8	1	1	1	1	1	1	1	1
F2	f3	0	0	1	1	1	1	0	0	F5	f9	0	1	1	1	1	1	1	0
	f4	1	1	1	0	0	1	1	1		f10	1	1	1	0	0	1	1	1
F3	f5	1	1	1	1	1	1	1	1										
	f6	1	1	1	1	1	1	1	1										

5. CONCLUSION

This research presents a diagnostic approach that utilizes logical equations to model constraints, particularly for manufacturing systems equipped with discrete actuators and sensors. The methodology views the plant as a collection of plant elements comprising sensors and their associated actuators. By employing fault-free models, the complexity of model construction is reduced, and there is no need to define faults a priori for diagnosis.

The goal is to take benefit of the composite structure of manufacturing systems. The use of fault free models reduces the model construction complexity since the fault behaviors in response to a predefined set of faults are not integrated in the system models and reduced modeling difficulties and risks of combinatorial explosion to discover errors. This diagnostic process is accomplished through a set of local diagnosers, each responsible for a specific area of the system or a designated component. This approach is modular and its complexity is reduced from $2Nc+Nu$ to $(Nu + 1).2Nc$, where Nu is the number of sensors and Nc is the number of commands for each actuator. Finally, the approach must be implemented into a programmable logic controller for a real and the goal is to incorporate the learning of system dynamics and expert knowledge to establish a preference order among events when the set of fault events contains more than one event.



REFERENCES

- [1] S. Reshmila and R. Devanathan, "Component level diagnosability of discrete event systems based on observations," *Innovations in Systems and Software Engineering*, vol. 19, no. 3, pp. 303–317, 2023, doi: 10.1007/s11334-022-00502-1.
- [2] B. Singh and P. K. Dubey, "Distributed power generation planning for distribution networks using electric vehicles: Systematic attention to challenges and opportunities," *Journal of Energy Storage*, vol. 48, p. 104030, Apr. 2022, doi: 10.1016/j.est.2022.104030.
- [3] P. K. Dubey, B. Singh, D. K. Patel, and D. Singh, "Distributed Generation Current Scenario in the World," *International Journal For Multidisciplinary Research*, vol. 5, no. 4, 2023, doi: 10.36948/ijfmr.2023.v05i04.4625.
- [4] V. Chandra and R. Kumar, "A discrete event systems modeling formalism based on event occurrence rules and precedences," *IEEE Transactions on Robotics and Automation*, vol. 17, no. 6, pp. 785–794, 2001, doi: 10.1109/70.975991.



- [5] G. Jiroveanu and R. K. Boel, "A distributed approach for fault detection and diagnosis based on Time Petri Nets," *Mathematics and Computers in Simulation*, vol. 70, no. 5–6, pp. 287–313, 2006, doi: 10.1016/j.matcom.2005.11.003.
- [6] A. Philippot, M. Sayed-Mouchaweh, and V. Carré-Ménétrier, "Candidates' generation for diagnosis of discrete manufacturing systems," *IFAC Proceedings Volumes*, vol. 42, no. 8, pp. 1575–1580, 2009, doi: 10.3182/20090630-4-ES-2003.00257.
- [7] M. O. Cordier and A. Grastien, "Exploiting independence in a decentralised and incremental approach of diagnosis," in *IJCAI International Joint Conference on Artificial Intelligence*, 2007, pp. 292–297.
- [8] M. S. Khireddine, N. Slimane, Y. Abdessemed, and M. T. Makhloufi, "Fault detection and diagnosis in induction motor using artificial intelligence technique," *MATEC Web of Conferences*, vol. 16, 2014, doi: 10.1051/mateconf/20141610004.
- [9] A. Philippot and B. Riera, "Fault Diagnosis of Discrete Event Systems Using Components Fault-Free models," in *20th International Workshop on Principles of Diagnosis DX'09*, Jun 2009, Stockholm, Sweden.
- [10] R. Jacob, J. J. Lesage, and J. M. Faure, "Overview of discrete event systems opacity: Models, validation, and quantification," *Annual Reviews in Control*, vol. 41, pp. 135–146, 2016, doi: 10.1016/j.arcontrol.2016.04.015.
- [11] J. Chen, C. Keroglou, C. N. Hadjicostis, and R. Kumar, "Revised Test for Stochastic Diagnosability of Discrete-Event Systems," *IEEE Transactions on Automation Science and Engineering*, vol. 15, no. 1, pp. 404–408, 2018, doi: 10.1109/TASE.2016.2551746.
- [12] A. Tajer, A. Philippot, and V. Carre-Menetrier, "Synthesis of optimal controller of discrete manufacturing systems by liveness extraction," 2012, doi: 10.1109/ICoCS.2012.6458578.
- [13] S. Chakkor, M. Baghour, and A. Hajraoui, "Wind turbine fault detection system in real time remote monitoring," *International Journal of Electrical and Computer Engineering*, vol. 4, no. 6, pp. 882–892, 2014, doi: 10.11591/ijece.v4i6.6479.
- [14] M. Khaleghi, M. Barkhordari Yazdi, A. Karimoddini, and M. Maghfoori Farsangi, "An inferring structure for MPO-based decentralized dynamic fault diagnosis," *IET Control Theory & Applications*, vol. 16, no. 2, pp. 182–191, 2022, doi: 10.1049/cth2.12215.
- [15] M. Sayed-Mouchaweh, "Decentralized fault free model approach for fault detection and isolation of discrete event systems," *European Journal of Control*, vol. 18, no. 1, pp. 82–93, 2012, doi: 10.3166/EJC.18.82-93.
- [16] J. Zaytoon and M. Sayed-Mouchaweh, "Discussion on Fault Diagnosis methods of Discrete Event Systems," *IFAC Proceedings Volumes (IFAC-PapersOnline)*, vol. 45, no. 29, pp. 9–12, 2012, doi: 10.3182/20121003-3-MX-4033.00005.
- [17] L. Dimitri, "Faulty patterns diagnosis for k-bounded non-Markovian timed stochastic Petri nets," *IFAC-PapersOnLine*, vol. 51, no. 11, pp. 235–240, 2018, doi: 10.1016/j.ifacol.2018.08.268.
- [18] M. Meng and J. E. Feng, "Function perturbations in Boolean networks with its application in a D. melanogaster gene network," *European Journal of Control*, vol. 20, no. 2, pp. 87–94, 2014, doi: 10.1016/j.ejcon.2014.01.001.
- [19] J. Zaytoon and S. Lafortune, "Overview of fault diagnosis methods for Discrete Event Systems," *Annual Reviews in Control*, vol. 37, no. 2, pp. 308–320, 2013, doi: 10.1016/j.arcontrol.2013.09.009.
- [20] B. Darkhovski and M. Staroswiecki, "A game-theoretic approach to decision in FDI," *IEEE Transactions on Automatic Control*, vol. 48, no. 5, pp. 853–858, 2003, doi: 10.1109/TAC.2003.811267.
- [21] R. Debouk, S. Lafortune, and D. Teneketzis, "Coordinated decentralized protocols for failure diagnosis of discrete event systems," in *Proceedings of the IEEE Conference on Decision and Control*, 1998, vol. 4, pp. 3763–3768, doi: 10.1023/A:1008335115538.
- [22] S. Gene and S. Lafortune, "Distributed diagnosis of discrete-event systems using Petri nets," *Lecture Notes in Computer Science (including subseries Lecture Notes in Artificial Intelligence and Lecture Notes in Bioinformatics)*, vol. 2679, pp. 316–336, 2003, doi: 10.1007/3-540-44919-1_21.
- [23] A. Cheriet, A. Bekri, A. Hazzab, and H. Gouabi, "Expert system based on fuzzy logic: Application on faults detection and diagnosis of DFIG," *International Journal of Power Electronics and Drive Systems*, vol. 9, no. 3, pp. 1081–1089, 2018, doi: 10.11591/ijpeds.v9.i3.pp1081-1089.
- [24] R. J. Patton, P. M. Frank, and R. N. Clark, Eds., *Issues of Fault Diagnosis for Dynamic Systems*. London: Springer London, 2000.
- [25] R. Jyothi, T. Holla, K. Uma Rao, and R. Jayapal, "Machine learning based multi class fault diagnosis tool for voltage source inverter driven induction motor," *International Journal of Power Electronics and Drive Systems*, vol. 12, no. 2, pp. 1205–1215, 2021, doi: 10.11591/ijpeds.v12.i2.pp1205-1215.
- [26] H. E. Garcia and T. S. Yoo, "Model-based detection of routing events in discrete flow networks," *Automatica*, vol. 41, no. 4, pp. 583–594, 2005, doi: 10.1016/j.automatica.2004.10.002.
- [27] C. N. Hadjicostis, "Probabilistic fault detection in finite-state machines based on state occupancy measurements," in *Proceedings of the IEEE Conference on Decision and Control*, 2002, vol. 4, pp. 3994–3999, doi: 10.1109/cdc.2002.1184991.
- [28] S. Yadav, M. S. I. Sudman, P. Kumar Dubey, R. Vijava Srinivas, R. Srisainath, and V. Chithra Devi, "Development of an GA-RBF based Model for Penetration of Electric Vehicles and its Projections," in *International Conference on Self Sustainable Artificial Intelligence Systems, ICSSAS 2023 - Proceedings*, 2023, pp. 1599–1604, doi: 10.1109/ICSSAS57918.2023.10331883.
- [29] P. K. Dubey, B. Singh, D. Singh, P. N. Verma, K. S. Verma, and Jahnavi, "Energy Storage Technologies: Types, Recent Trends, and Development," in *2024 3rd International Conference on Power Electronics and IoT Applications in Renewable Energy and its Control, PARC 2024*, 2024, pp. 1–7, doi: 10.1109/PARC59193.2024.10486412.
- [30] B. Singh, P. K. Dubey, and S. N. Singh, "Recent Optimization Techniques for Coordinated Control of Electric Vehicles in Super Smart Power Grids Network: A State of the Art," 2022, doi: 10.1109/UPCON56432.2022.9986471.
- [31] P. K. Dubey, B. Singh, V. Kumar, and D. Singh, "A novel approach for comparative analysis of distributed generations and electric vehicles in distribution systems," *Electrical Engineering*, vol. 106, no. 3, pp. 2371–2390, 2024, doi: 10.1007/s00202-023-02072-2.

BIOGRAPHIES OF AUTHORS





Hireche Slimane    was born in 1985 at Oran-Algeria. He received the electrical engineering diploma option: Control from the University of Bechar, Algeria in 2008, and the magister degree option: Automatic from the University of Bechar, Algeria in 2013. He is a Ph.D. student in the Electrical Engineering at the University of Bechar since 2014. His research interests include diagnostic automatic system, electronic, command, and automatic. He can be contacted at email: etn.sliman@gmail.com.





Mohamed Habbab    was born in 1969 at Relizane-Algeria. He received the state engineer degree in Electronic Engineering in 1994 from the University of Sciences and Technology of Oran (USTO), Algeria and the M.Sc. degree as well as the Ph.D. degree in the Electrical Engineering from University Tahri Mohamed, Bechar, Algeria in 2015 and 2018 respectively. He is currently professor of Electrical Engineering at University Tahri Mohamed Bechar, Algeria. His research interests include power electronics, and artificial intelligence and their applications. He can be contacted at email: habbab.mohamed@univ-bechar.dz.





Abdeldjebbar Hazzab    received the state engineer degree in Electrical Engineering in 1995 from the University of Sciences and Technology of Oran (USTO), Algeria, the M.Sc. degree from the Electrical Engineering Institute of the USTO in 1999, and the Ph.D. degree from the Electrical Engineering Institute of the USTO in 2006. He is currently professor of Electrical Engineering at University of Bechar, Algeria, where he is director of the research laboratory of control analysis and optimization of the Electro-Energetic Systems. He is also an invited professor from École de Technologie Supérieure (ETS), Université, Montréal, Canada. His research interests include power electronics, electric drives control, and artificial intelligence and their applications. He can be contacted at email: hazzab.abdeldjebbar@etsmtl.ca or abdeldjebbar.hazzab@gmail.com.





Ahmed Khalil Moussaoui    was born in Bachar, Algeria, in 1988. He got L.Sc. and M.Sc. degrees in Electrical and Electronic Engineering from the University of Bashar, Algeria, in 2010 and 2012, respectively. He has been working his Ph.D. since September 2014 in the Department of Electrical and Electronic Engineering. He is currently a research fellow in Laboratory Control and Analysis and Electrical Power Improvement Systems, Department of Electrical and Electronic Engineering, Bechar University. His main research activity focuses on drones, programming, and process control. He can be contacted at email: khalilmoussaoui88@gmail.com.





Ambrish Chandra    got B.E. degree from the University of Roorkee, India, in 1977, the M.Tech. degree from IIT Delhi, in 1980, and the Ph.D. degree from the University of Calgary, in 1987. Before joining as an associate professor at the ÉTS, Montreal, in 1994, he worked as an associate professor at IITR. Since 1999, he has been a full professor of electrical engineering with ÉTS. From 2012 to 2015, he was the director of the Multidisciplinary Graduate Program on Renewable Energy and Energy Efficiency with ÉTS. He is currently the director of the master program in Electrical Engineering. The primary focus of his work is related to the advancement of new theory and control algorithms for power electronic converters for power quality improvement in distribution systems and integration of renewable energy sources. He can be contacted at email: ambrish.chandra@etsmtl.ca.



Hicham Gouabi    was born on the 20th November 1992 in Bechar, Algeria. He received the master degree in Automation of Industrial Processes: Automatic Control from the M'Hamed Bougara University, Boumerdes, Algeria in 2016. He is a member of the Control Analysis and Optimization of the Electro-Energetic Systems (CAOSEE) Laboratory since 2016. His research interests cover, power electronics, control of multilevel converters, artificial intelligence, and their applications. He can be contacted at email: gouabi.hicham@univ-bechar.dz.



Alhachemi Moulay Abdellah    was born on the 2nd of January 1999 in Adrar, Algeria. He received an M.S. degree in Automation and Industrial Computing from Tahri Mohammed University in 2022. He has been a member of the Control Analysis and Optimization of the Electro-Energetic Systems (CAOSEE) Laboratory since 2023. His research interests cover, power electronics, control of multilevel converters, artificial intelligence, and renewable energy. He can be contacted at email: alhachemi.abdellah@univ-bechar.dz.